

# TYPHOON

## ASSEMBLY AND INSTALLATION INSTRUCTIONS

**S.R. Smith™**



**CORPORATE HEADQUARTERS  
WESTERN SALES AND MANUFACTURING PLANT  
P.O. Box 400 • 1017 SW Berg Parkway  
Canby, Oregon 97013  
Phone: (503) 266-2231 • Fax: (503) 266-4334  
[www.srsmith.com](http://www.srsmith.com)**

## Table of Contents

<u>Topic</u>	<u>Page #</u>
INTRODUCTION.....	2
TYPHOON PARTS LIST .....	4
ASSEMBLY INSTRUCTIONS .....	5
PLUMBING INSTRUCTIONS.....	12
ON-DECK MOUNTING INSTRUCTIONS.....	13
MANUFACTURER'S PLACEMENT INSTRUCTIONS.....	14

## **INTRODUCTION**

---



**DANGER – FAILURE TO FOLLOW THESE WARNINGS, INSTRUCTIONS AND THE OWNER'S MANUAL MAY RESULT IN SERIOUS INJURY OR DEATH**

THE TYPHOON™ SLIDE IS DESIGNED AND MANUFACTURED FOR INSTALLATION AND USE ON INGROUND SWIMMING POOLS ONLY. DO NOT INSTALL THE TYPHOON SLIDE ON ABOVE GROUND POOLS, HOUSEBOATS, BOAT DOCKS, FLOATING DOCKS OR PLATFORMS, OR OTHER BODIES OF WATER SUCH AS LAKES, PONDS, RIVERS, ETC. PROPER ASSEMBLY, INSTALLATION, USE, AND SUPERVISION IS ESSENTIAL FOR PROPER OPERATION AND TO REDUCE THE RISK OF SERIOUS INJURY OR DEATH.

CHECK INSIDE ALL BOXES AND PACKAGING MATERIALS FOR PARTS. BEFORE BEGINNING ASSEMBLY, READ ALL INSTRUCTIONS AND IDENTIFY PARTS USING THE FIGURES AND PARTS LISTED IN THIS DOCUMENT. IT IS CRITICAL THAT ALL PARTS BE CAREFULLY INSPECTED BY THE INSTALLER PRIOR TO INSTALLATION TO ENSURE THAT NO DAMAGE OCCURRED IN TRANSIT AND THAT A DAMAGED PART IS NOT USED. PROPER INSTALLATION CANNOT BE OVERSTRESSED, AS AN IMPROPER INSTALLATION VOIDS S.R. SMITH'S WARRANTY AND MAY AFFECT THE SAFETY OF THE USER.

INSTALLER MUST GIVE TO SLIDE OWNER: TYPHOON SLIDE INSTALLATION AND OWNER'S MANUAL, THE WARRANTY CARD, AND ANSWER ALL QUESTIONS REGARDING SAFE AND PROPER USE AND SLIDE MAINTENANCE.

FOR COMPLETE SLIDE SAFETY INFORMATION REFER TO THE OWNER'S MANUAL.

### **INSTALLED TYPHOON STRUCTURAL & INSTALLATION CHECKLIST (INSTALLER TO REVIEW WITH SLIDE OWNER UPON COMPLETION OF SLIDE INSTALLATION)**

1. INSPECT THE RUNWAY FOR VISIBLE CRACKS OR TEARS.
2. INSPECT THE SLIDE FOR SHARP EDGES, PROTRUSIONS, CRACKS OR TEARS.
3. INSPECT ALL FASTENERS TO MAKE SURE THEY ARE FULLY TIGHTENED.
4. INSPECT THE LADDER FOR RIGIDITY AND ATTACHMENT.
5. MEASURE THE FOLLOWING DIMENSIONS AND COMPARE WITH THE MANUFACTURER'S PLACEMENT INSTRUCTIONS ON PAGES 14 AND 15.
  - MEASURE THE DEPTH OF WATER IN FRONT OF THE SLIDE EXIT. (4'-6" (1370 mm) MIN. DEPTH AT A DISTANCE OF 4'-6" (1370 mm) FROM EXIT END OF SLIDE.)
  - MEASURE THE HEIGHT OF THE SLIDE RUNWAY EXIT ABOVE THE WATER. (20" (508 mm) MAX.)
  - MEASURE THE DISTANCE BETWEEN THE SLIDE CENTERLINE AND THE EDGE OF OTHER POOL EQUIPMENT.
6. OBSERVE THE POSITION OF THE EXIT OF THE SLIDE AS SHOWN IN FIGURES 13, 14 AND 16 ON PAGES 14 AND 15.

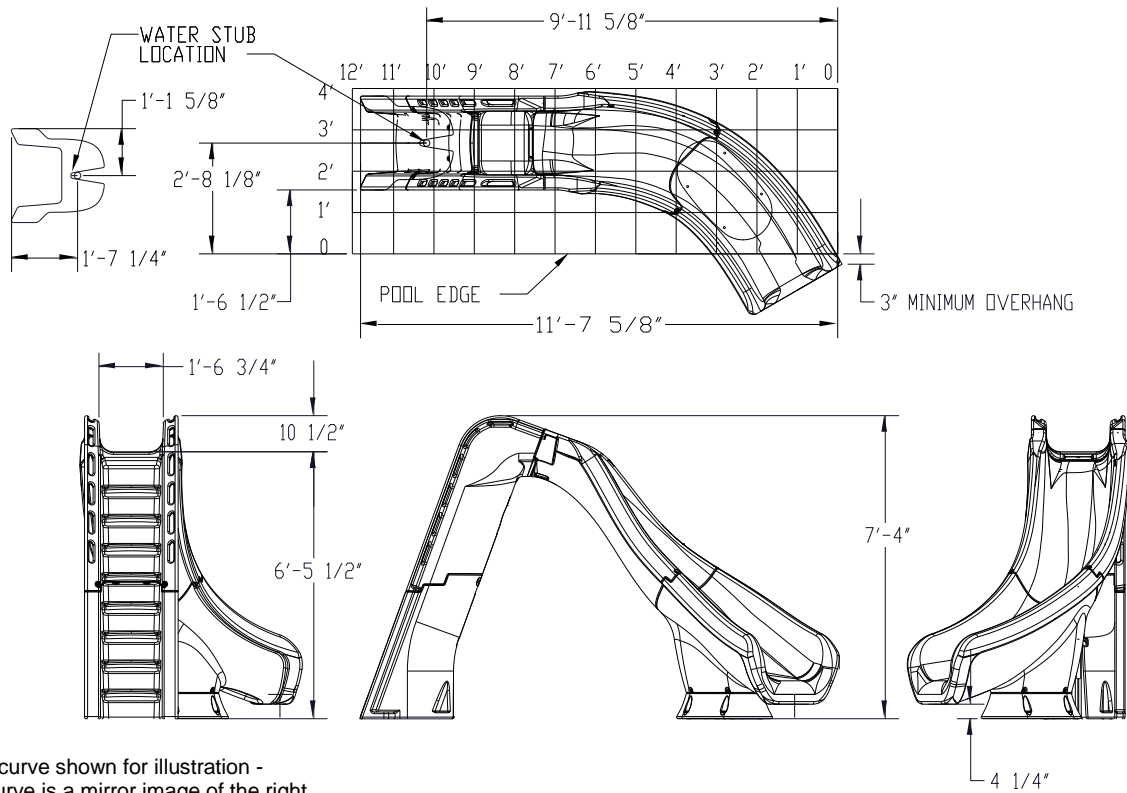

Right curve shown for illustration -  
 Left curve is a mirror image of the right.

**For SI: 1 degree = 0.017 rad, 1 inch = 25.4 mm, 1 foot = 304.8 mm**

**FIGURE 1**

# TYPHOON PARTS LIST

ITEM #	PART #	DESCRIPTION	QTY.
1	5-139	3/8" Hex Nut	10 ea.
2	5-151	3/8" Lock Washer	10 ea.
3	05-14-115	1/2" Lock Washer	8 ea.
4	5-145	3/8" Flat Washer	24 ea.
5	5-246	3/8" x 2-3/4" Carriage Bolt	2 ea.
6	5-247	3/8" x 3" Button Head Cap Screw	4 ea.
7	5-239	3/8" x 2-1/2" Stud	4 ea.
8	5-240	3/8" x 3-1/2" Lag Screw	6 ea.
9	5-237	3/8" x 5" Button Head Cap Screw	2 ea.
10	5-248	3/8" x 3.5" Hex Head Cap Screw	2 ea.
11	5-242	#14" x 1" Pan Head Tapping Screw	6 ea.
12	5-241	1/2" x 5" Anchor Stud	8 ea.
13	05-782	1.5" PVC Pipe Strap	2 ea.
14	05-767	1" Pipe Clamp	2 ea.
15	05-770	1" Ball Valve Gray	1 ea.
16	05-784	1" Coupling	1 ea.
17	05-773	Garden Hose Adapter	1 ea.
18	8-532	.5" HIGH X .5" WIDE X 32" LONG RUBBER GASKET	1 ea.
19	8-531	.375" HIGH X .5" WIDE X 33" LONG RUBBER GASKET	1 ea.
20	05-786-1	1" PVC Flex Hose, 16" long (Not Shown)	1 ea.
21	05-786-2	1" PVC Flex Hose, 68" long (Not Shown)	1 ea.

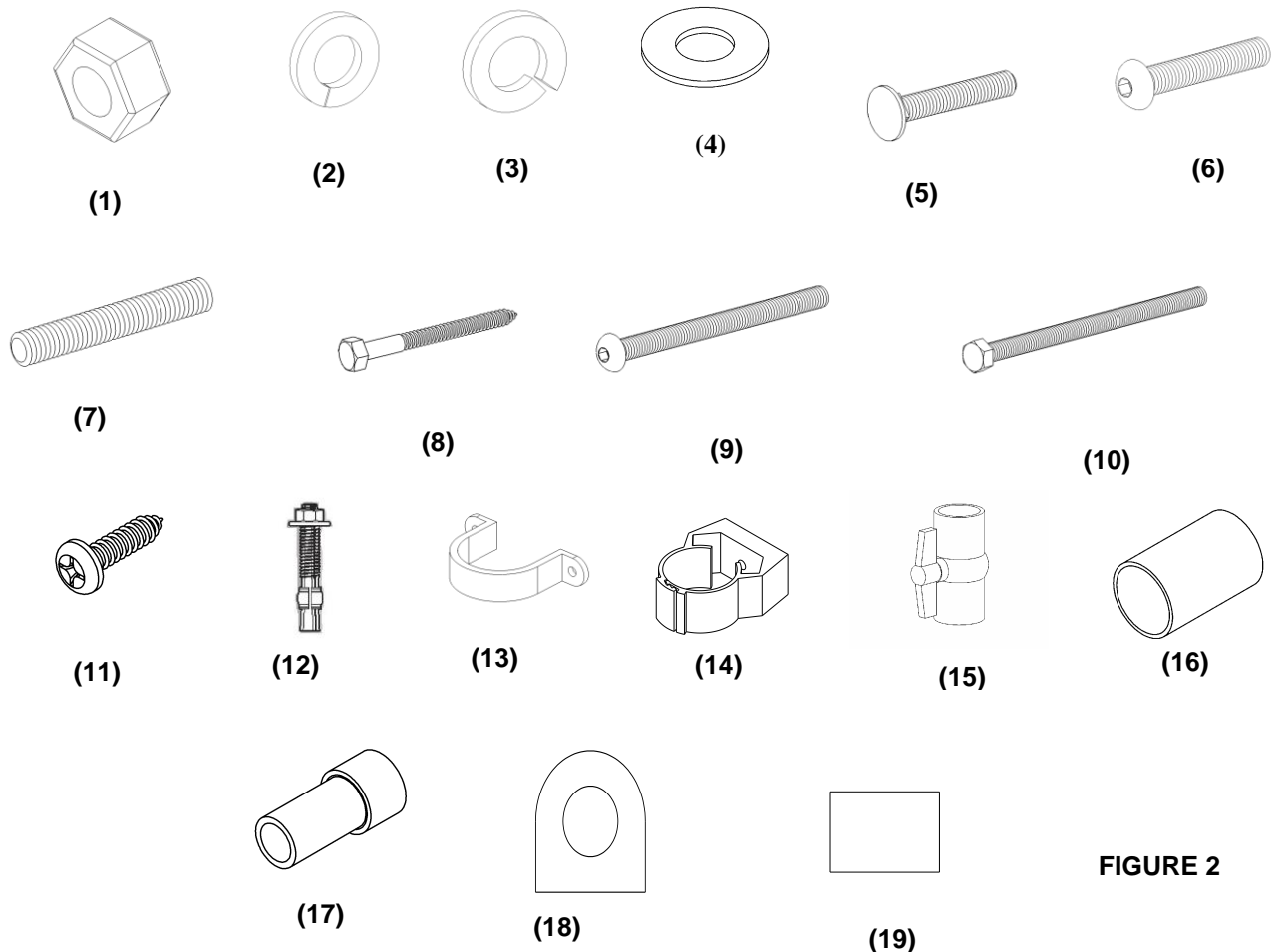

FIGURE 2

## **ASSEMBLY INSTRUCTIONS**

### **Tools Required:**

- |                                    |                            |
|------------------------------------|----------------------------|
| 1. Ratchet handle                  | 8. 1/4" (6 mm) drill bit   |
| 2. 9/16" deep socket               | 9. Power drill             |
| 3. 9/16" wrench                    | 10. PVC pipe primer & glue |
| 4. 3/4" socket or wrench           | 11. Anti-seize             |
| 5. 7/32" allen wrench              | 12. Saw to cut PVC pipe    |
| 6. Phillips head screwdriver       | 13. Knife                  |
| 7. 1/2" (13 mm) concrete drill bit | 14. Level                  |

### **Gasket Installation:**

- Most of the gasket material has been installed at the factory, however additional gasket has been provided in case any gasket has fallen off during shipping. If gasket installation is required, follow the instructions below. The gasket on the face of the ladder is not installed in the factory, but detailed instructions are provided in step 8 on page 8.
- Apply gasket (PN 8-532) in the required locations as shown in the figures below.
- Place gasket along the section to determine the length needed.
- Cut gasket to appropriate length.
- Remove backing and adhere gasket to slide.
- All gaskets below are applied as shown in the gasket section detail (see step 8 for further details on installing the ladder gasket, PN 8-531)

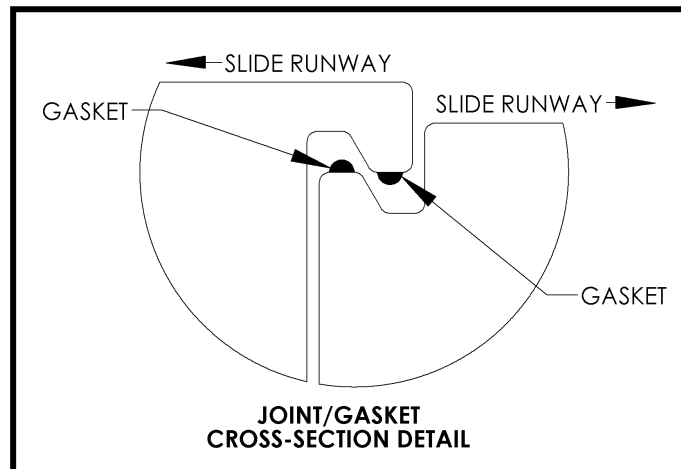

**FIGURE 3**

## Assembly:

### Before getting started:

- **To prevent damage to the parts during assembly, it is recommended that cardboard or some other protective barrier is laid down on the ground where the slide is to be assembled.**
- **Verify that the gasket material is affixed to the slide parts as shown on page 4**
- **During assembly, be sure to apply a thin coat of anti-seize compound to the threads of all fasteners. Anti-seize helps aid in assembly, prevents galling, and improves corrosion resistance.**

- 1) Assemble the pedestal part to the runway exit section as shown in Figure 4. Attach the pedestal part to the runway exit section by inserting the two lag screws into the holes located in the bottom of the pedestal.
- 2) Before inserting the lag bolts into the side of the runway exit part, 1/4" (6 mm) pilot holes must be drilled into the center of each of the recesses. The pilot holes should be drilled through both the runway exit section and into the pedestal.

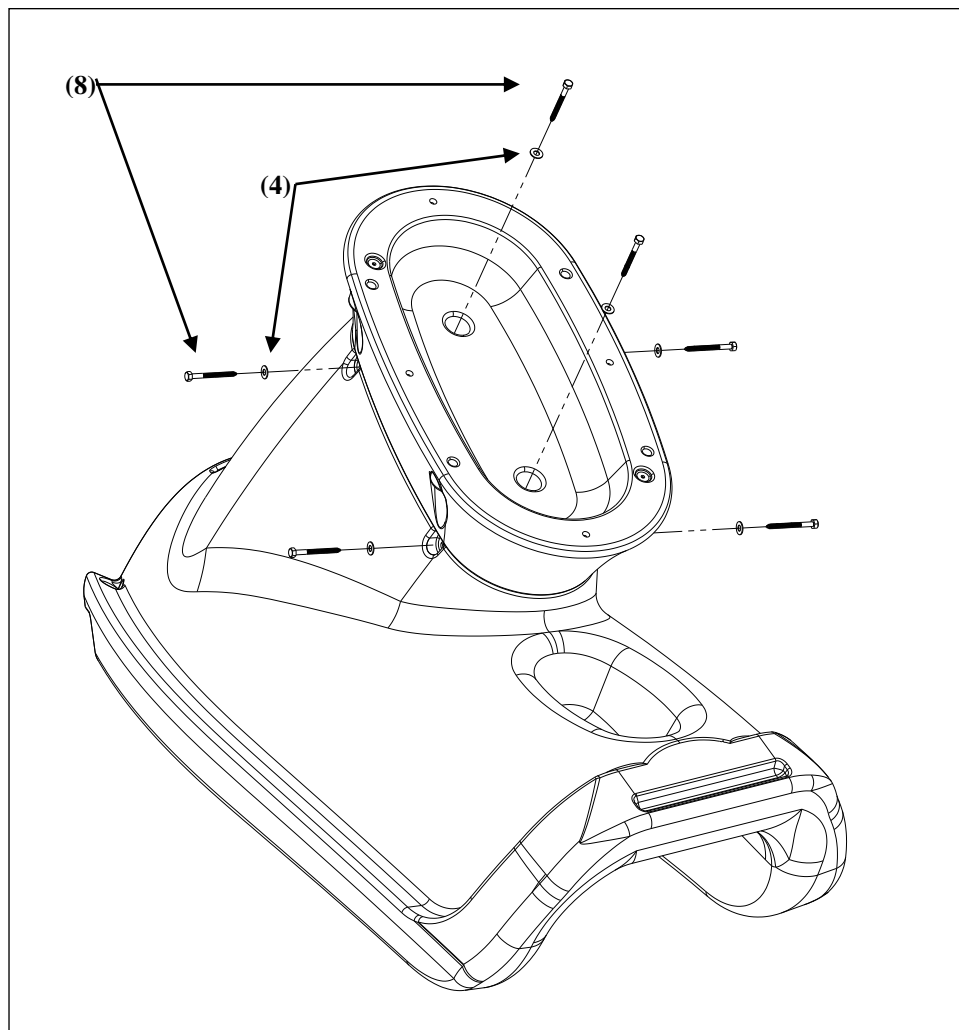

**FIGURE 4**

- 3) Place the assembled runway exit section and pedestal upright so that the pedestal is resting on the ground. **Notes: It may take more than one person to perform this step. Verify that the gasket material is properly attached before assembling the parts.**
- 4) Insert the threaded studs into each of the threaded inserts as shown in Figure 5. The studs should be screwed in by hand until they reach the bottom of the insert. If the studs cannot be threaded in by hand, pliers may be used. Before using pliers, a piece of cloth should be placed over the stud to protect the threads from damage. **Note: Be sure to apply anti-seize to all fasteners to prevent galling.**

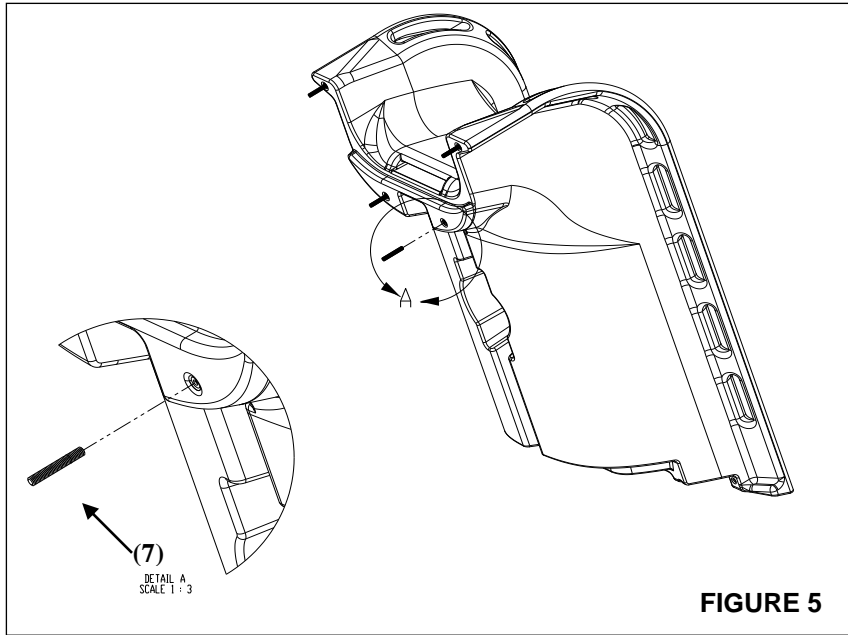

5) Assemble the top ladder section to the lower ladder section as shown in Figure 6. Insert the two button head cap screws into the threaded inserts as shown in Figure 6. **Do not fully tighten the screws at this point; just get the screws started into the threaded inserts. Note: Be sure to apply anti-seize to all fasteners to prevent galling.**

6) Insert the button head cap screws into the back side of the ladder as shown in Figure 7. Tighten the screws until snug. Go back and fully tighten the screws from Step 7. **Note: Be sure to apply anti-seize to all fasteners to prevent galling.**

7) Insert the two carriage bolts into the steps as shown in Figure 6. Tighten the nuts onto the carriage bolt until the lock washer is fully compressed. **Note: Be sure to apply anti-seize to all fasteners to prevent galling.**

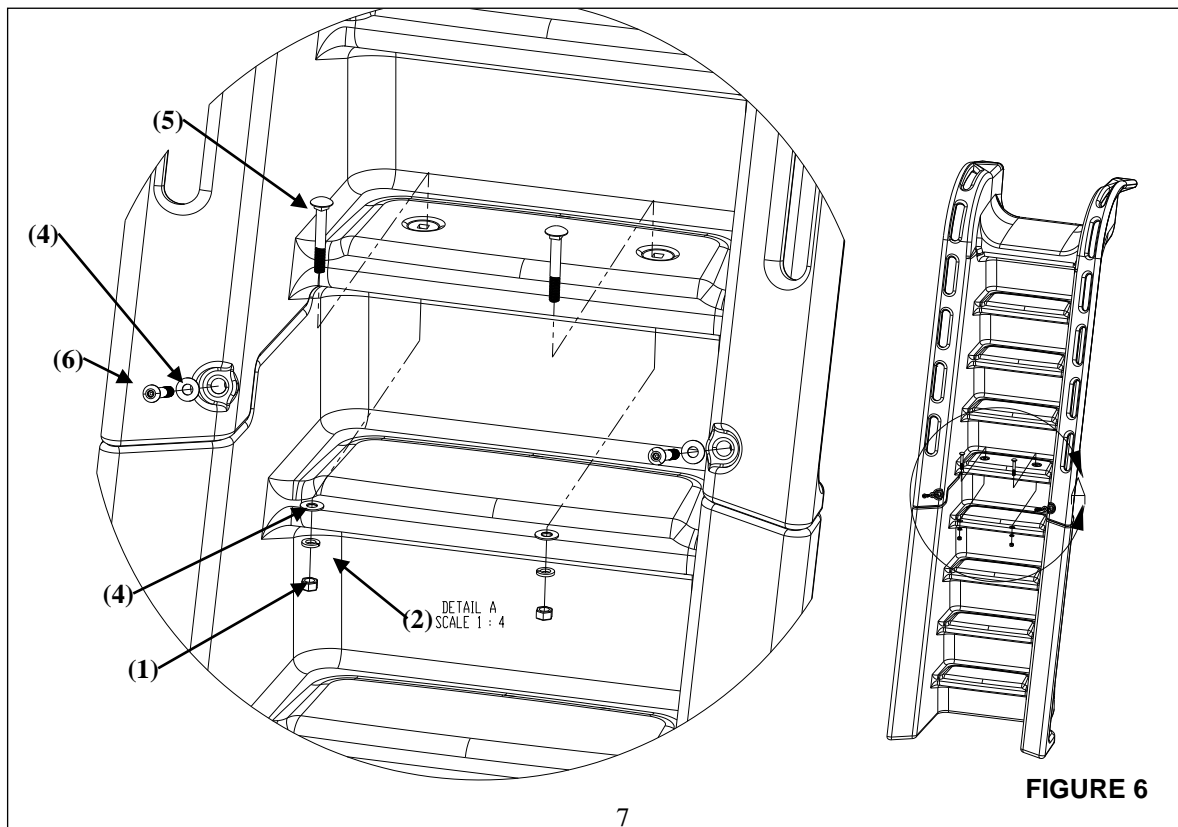

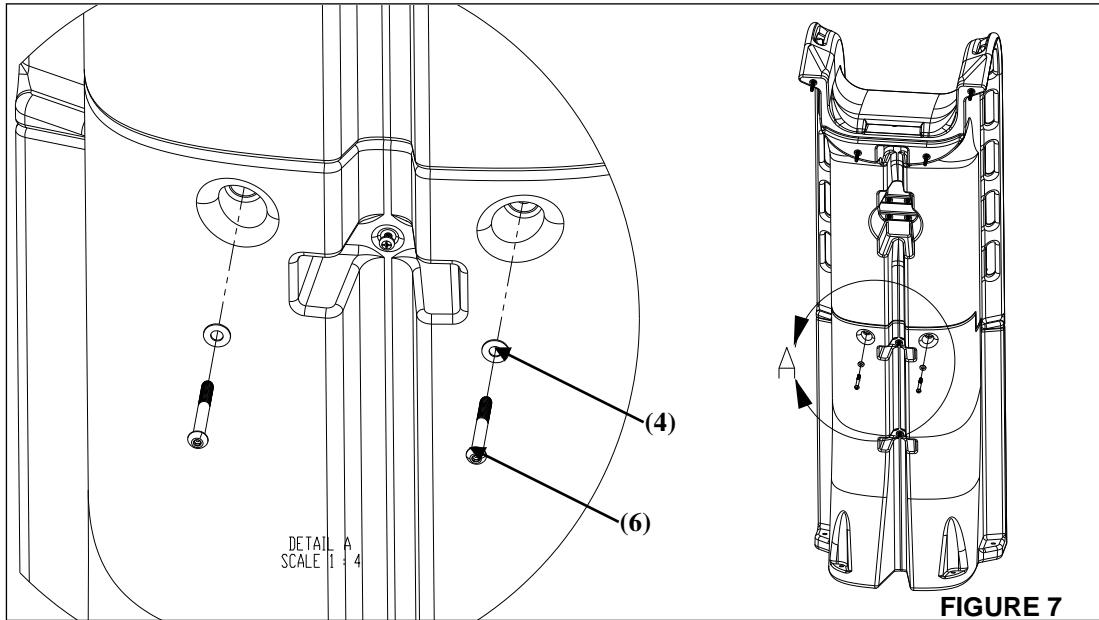

**FIGURE 7**

- 8) Before getting started, be sure that the joint surfaces of the top runway and ladder sections are clean and dry. Unroll the gasket material and hold so that that length of the gasket is centered on the center of the ladder joint. With the exposed adhesive side of the gasket facing the ladder joint surface, apply the gasket starting at the center of the part, working outward to the sides. Be sure that the bottom edge of the gasket material is held against the shelf on the ladder part during installation, see reference images below. Do not make too tight of a bend radius with the gasket when transitioning the gasket up the vertical edges of the joint. The transition radius should be as large as possible. Making too tight of a bend radius will cause the gasket to kink and possibly leak. The gasket should be centered on the available space in the vertical area of the joint, see reference images below. Once the gasket is in place, firmly press down on the gasket in all locations to ensure that the gasket has completely adhered to the ladder joint surface. Remove the paper backing on the gasket to expose the adhesive. Use caution not to remove the adhesive strip from the gasket when removing the paper backing.

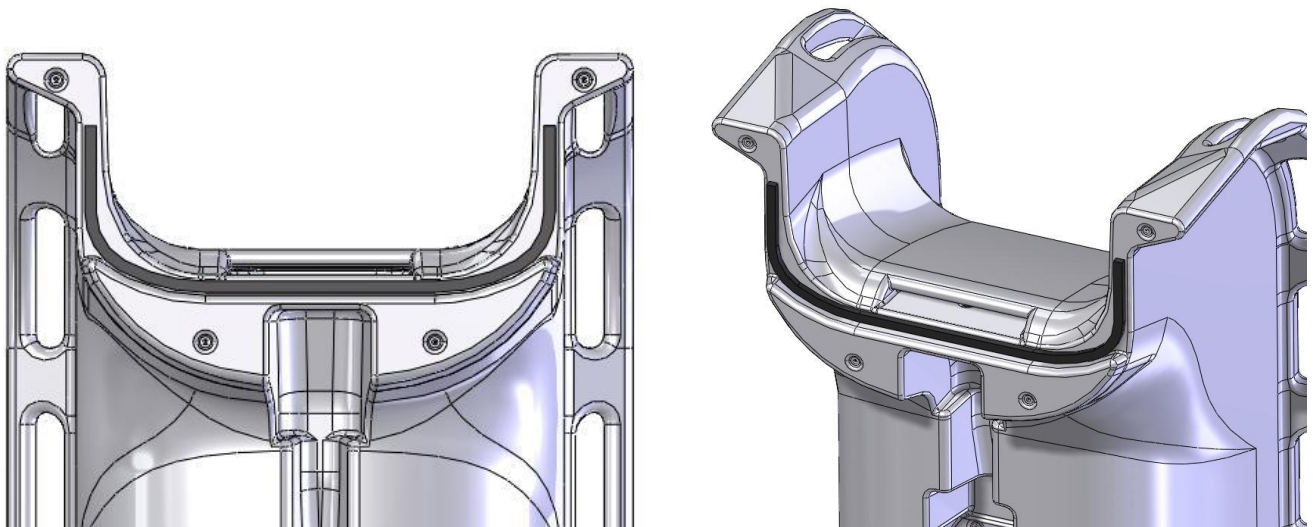

**FIGURE 8A**



- 9) Align the threaded studs sticking out of the top ladder section with the holes in the upper runway section. Attach the runway to the ladder using the hardware shown in Figure 8B. Tighten until the lock washer is fully compressed. **Notes: It may take more than one person to perform this step. Verify that the gasket material is properly attached before assembling the parts. Be sure to apply anti-seize to all fasteners to prevent galling.**

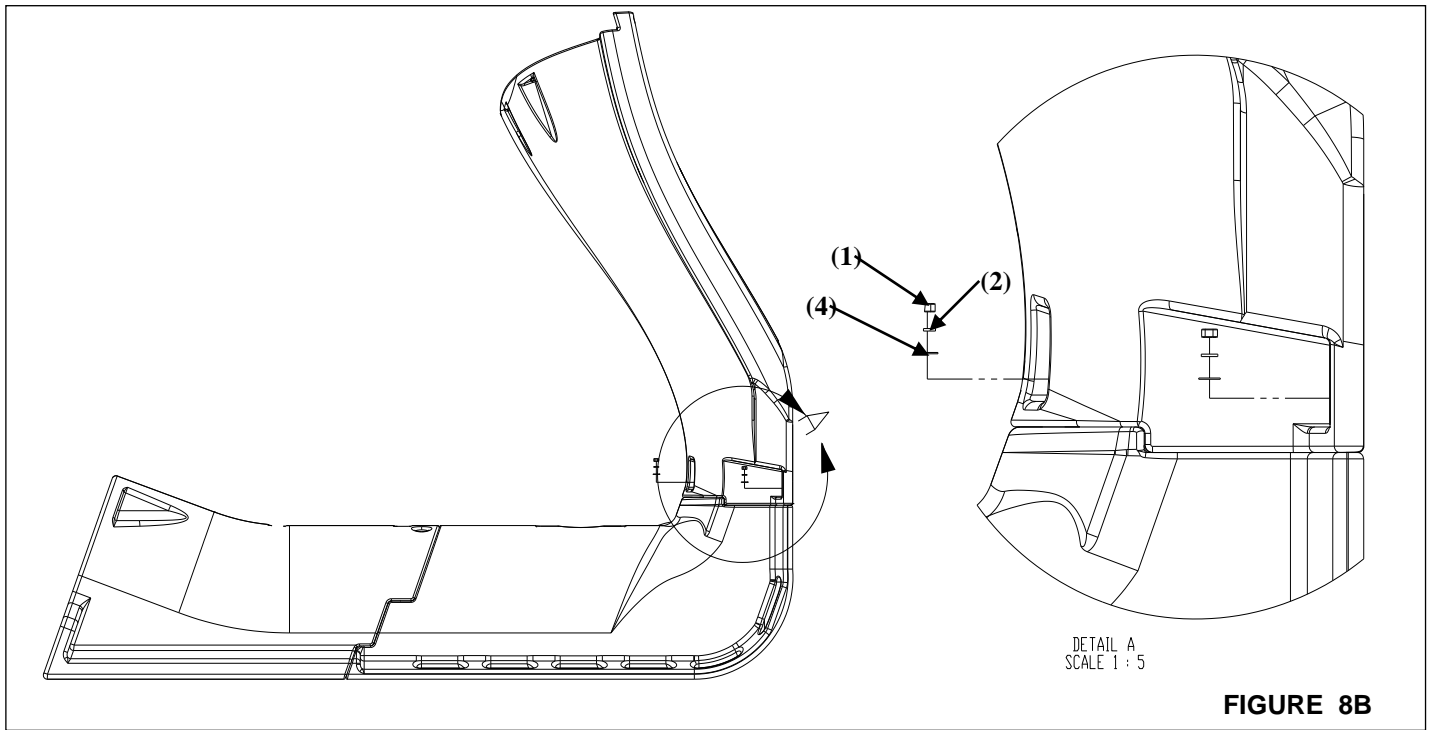

- 10) Stand the ladder upright and attach the runway entrance section to the runway exit section using the button head cap screws as shown in Figure 9. Tighten the button head cap screws until the lock washers are compressed. **Notes: It may take more than one person to perform this step. Be sure to apply anti-seize to all fasteners to prevent galling.**
- 11) Once the button head screws are tightened, insert the hex head cap screws into the underside of the runway as shown in Figure 9. Tighten the hex head cap screws until the lock washers are compressed. **Note: Be sure to apply anti-seize to all fasteners to prevent galling.**

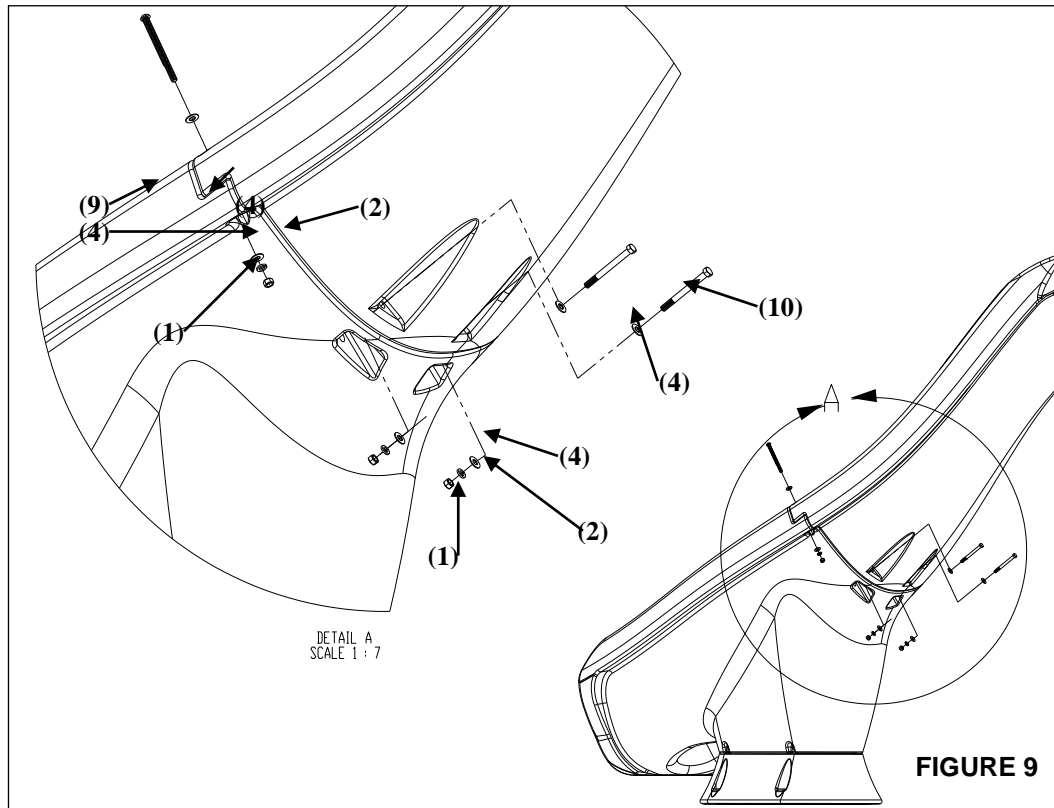

- 12) First, fully assemble the water system components in the order shown in Figure 10 without gluing anything together. Assemble the water system parts to the ladder to ensure that everything fits before proceeding. Be sure that the ball valve is properly centered in the recess of the ladder.
- 13) Attach the pipe clamps to the ladder as shown in Figure 10, detail B.
- 14) Use PVC primer and glue to permanently assemble the parts together as in step 11.
- 15) Glue the top end of the PVC hose into the fitting in the ladder.
- 16) Use the pipe straps to fasten the ball valve into the ladder recess as shown in Figure 11, detail A.
- 17) Insert the hose into the hose clamps by firmly pushing the hose into the back of the clamp.

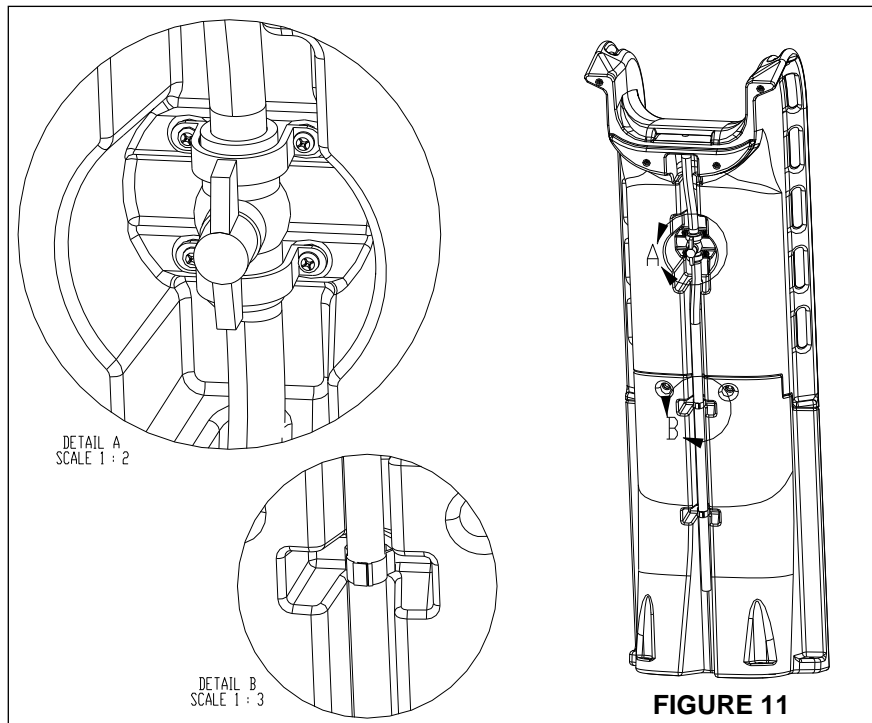
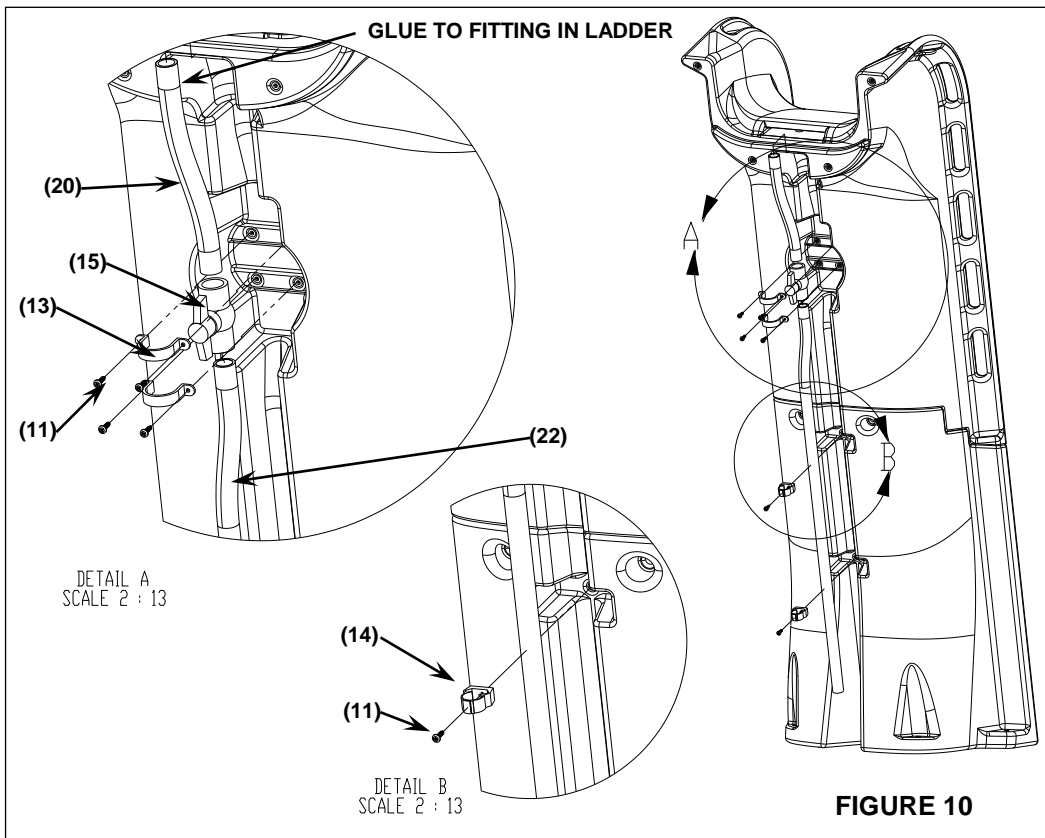

## PLUMBING INSTRUCTIONS

1. The Typhoon is designed for a water supply line of 1" pipe. Plumb from pool return line with a 1" PVC pipe "stubbed up" at the deck positioned at the base of the ladder. Refer to FIGURE 1 on page 2. FIGURE 1 is for reference only. Assembled slide should be placed in its correct location and the "stub up" location marked and installed before mounting the slide to the deck. "Stub up" should be dark grey PVC to match the plumbing assembly of the slide. **Note: "Stub up" should extend above the deck 18" (457 mm) in height. It can be cut to proper length further in the installation process.**
2. If a garden hose is to be used, a garden hose adapter fitting is included with the slide. Assemble the pieces as shown in Figure 12 and attach to the end of the PVC plumbing assembly at the base of the ladder.
3. Proceed to the following section for **ON-DECK MOUNTING**. After the slide has been mounted to the deck, attach the "stub up" as necessary to the plumbing assembly installed in the ladder.
4. The Typhoon can handle up to 20 gallons per minute (75 L/min). Water flow is to be regulated using the ball valve near the base of the ladder.

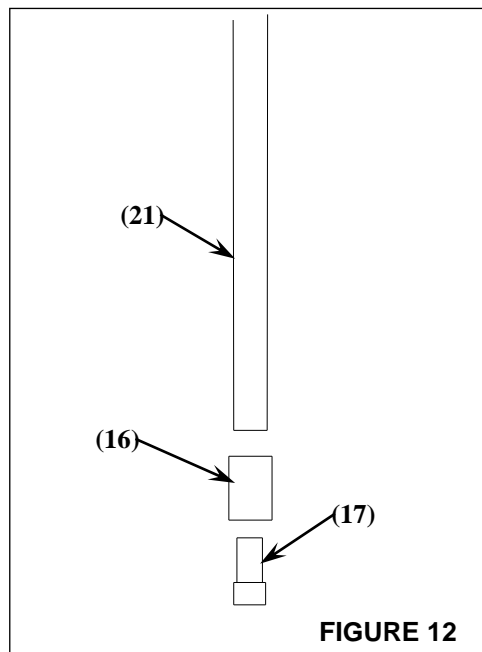

## **ON-DECK MOUNTING INSTRUCTIONS**

1. Place the assembled slide on the deck relative to the pool wall. Ensure that the exit flume clears any coping. Slide may be angled slightly providing all dimensions are maintained as noted in the **Manufacturer's Placement Instructions** noted in the following section.
2. With the slide in its proper location, center punch or otherwise mark through the (8) mounting holes at the bottom of the ladder and pedestal so that a visible mark is apparent on the concrete.
3. Move the assembled slide aside to facilitate drilling of the anchoring holes.

4. Using a power drill and a 1/2" (13 mm) concrete drill bit, drill the holes to a depth of 4" (102 mm). Use tape or a marking on the drill bit to ensure that the hole for the anchor is drilled to the required depth. Maintain drill hole straight and perpendicular for proper holding strength of anchor stud.

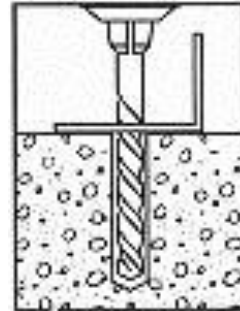

5. Clear the holes of all debris. Assemble anchor with nut and washer so that the top of the nut is flush with the top of the anchor. **Move the slide over the holes before inserting the anchors.** Drive anchor through the slide mounting holes so that nut and washer are flush with the surface material.

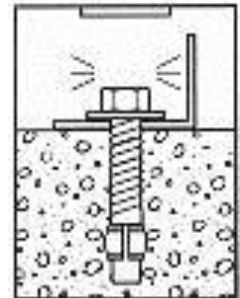

6. Ensure the slide ladder is plumb by placing a level on a ladder tread. If necessary, shims can be provided by S.R. Smith to place beneath the base of the ladder to ensure it is plumb due to varying deck slopes. Please call 1.800.824.4387 if shims are needed.

7. Expand anchor by tightening nut 3 to 5 turns. Once anchor is set remove nut and install a lock washer, item # (3), and retighten nut to a torque of 25 ft.-lbs (33.9 N-m).

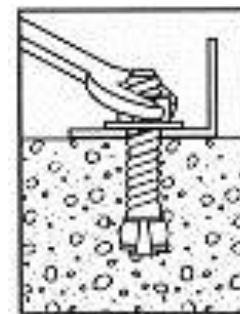

# MANUFACTURER'S PLACEMENT INSTRUCTIONS

1. The critical dimensions for placement of the TYPHOON are as shown in FIGURE 'S 13 and 14.
  - A. The slide exit runway surface shall not exceed twenty inches (20") (508 mm) above the water surface as shown in FIGURE 13.
  - B. The slide shall be positioned so that all water flowing off the runway exit drops into the pool. The recommended overhang is 4 inches (102 mm).
  - C. The minimum depth of water below the exit lip of the slide shall be three feet (3') (914 mm) and increase to four feet six inches (4'-6") (1371 mm) at Pt. A, which is a distance of four feet six inches (4'-6") (1371 mm) from the exit lip of the slide as shown in FIGURE 13.
  - D. A minimum depth of four feet six inches (4'-6") (1371 mm) shall be maintained at a distance of nine feet (9') (2743 mm) along the extended centerline of the slide from Pt. A. as shown in FIGURE 13.

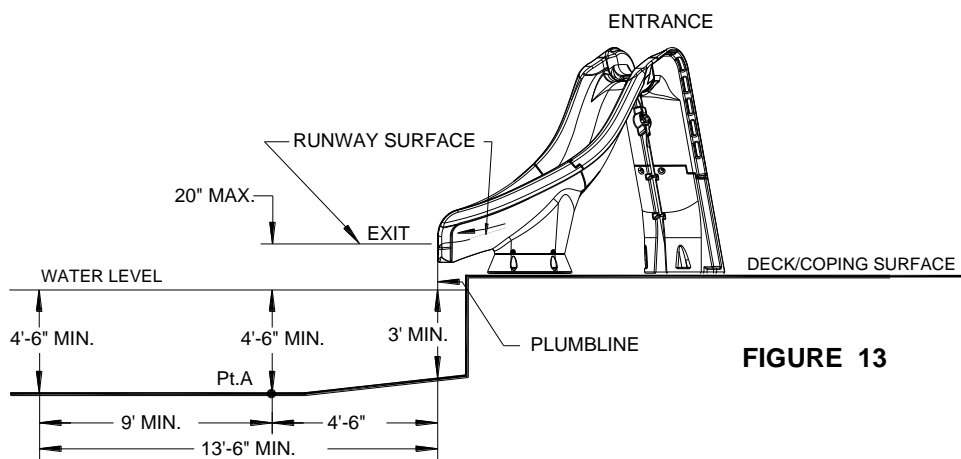

FIGURE 13

For SI: 1 degree = 0.017 rad, 1 inch = 25.4 mm, 1 foot = 304.8 mm

2. A minimum clearance area in front of the slide shall be maintained at all times as follows:

The minimum clearance distance on either side of the extended centerline of the slide runway shall not be less than three feet six inches (3'-6") (1067 mm) at a point no less than two feet six inches (2'-6") (762 mm) from the exit lip of the slide and extending a distance of thirteen feet six inches (13'-6") (4115 mm) in front of the slide as shown in FIGURE 14.

### 3. SLIDE PLACEMENT INSTRUCTIONS FOR INSTALLATIONS ON POOLS WITH OTHER SLIDES AND/OR DIVING BOARDS

- A. The minimum clearance area in front of a properly installed diving board on an inground swimming pool is a minimum distance of three feet six inches (3'-6") (1067 mm) on either side of the board's centerline as shown in FIGURE 15. Pt. C extends a minimum distance of "C" from the tip end of the board as shown in FIGURE 15. The width distance "W" on either side of Pt. C is given in CHART 1 and shown in FIGURE 15.

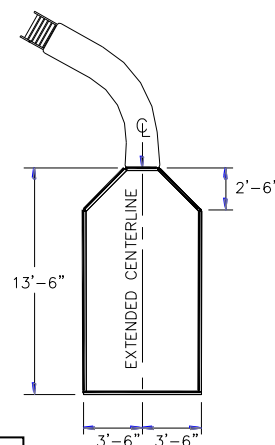

SLIDE  
MINIMUM CLEARANCE AREA

FIGURE 14

For SI: 1 degree = 0.017 rad, 1 inch = 25.4 mm, 1 foot = 304.8 mm

## CHART 1

BOARD MINIMUM CLEARANCE AREA		
POOL TYPE	"C" DIMENSION	"W" DIMENSION
I	14'-6"	5'-0"
II	14'-6"	6'-0"
III	16'-6"	6'-0"
IV	18'-6"	7'-6"
V	21'-0"	7'-6"

For SI: 1 degree = 0.017 rad, 1 inch = 25.4 mm, 1 foot = 304.8 mm

See Article 5 contained in ANSI/APSP/ICC-5 2011 STANDARD FOR RESIDENTIAL INGROUND SWIMMING POOLS and refer to FIGURE 3 and Table 1 for Minimum Water Envelope Dimensions AB, BC and Width at Point C.

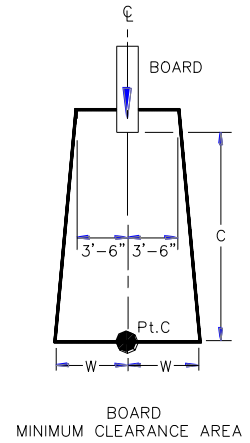
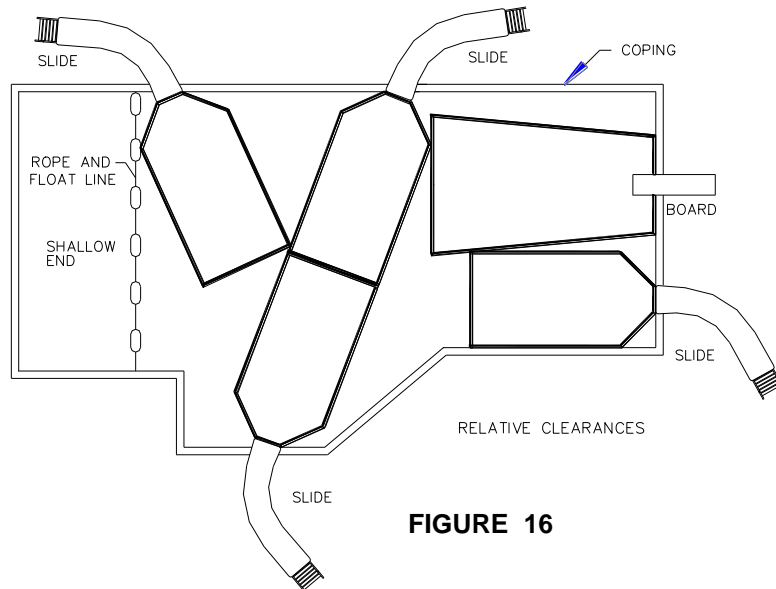

**FIGURE 15**

"C" DIMENSION FOR BOARD = AB + BC

"W" DIMENSION FOR BOARD = WIDTH AT PT.C

- B. The minimum clearance area of a slide or diving board shall not intersect any coping or rope and float line as shown in FIGURE 16. The minimum clearance area of a slide or diving board may intersect each other provided that they are not used simultaneously.



**FIGURE 16**