

ITEM NO.	PART NUMBER	DESCRIPTION	QTY.
1	196mm pipe		2
2	300mm pipe		2
3	tee		28
4	260mm pipe		2
5	626mm pipe		2
6	304mm pipe		4
7	female socket		4
8	platform		1
9	wheel bolt M8x50		3
10	wheel tee		2
11	wheel		2
12	M8 nut		2
13	flat washer		4
14	187mm pipe		2
15	1366mm pipe		2
16	elbow		4
17	socket		4
18	bumper		6
19	207mm pipe		4
20	116mm pipe		2
21	66mm sleeve		14
22	177mm pipe		2
23	1239mm pipe		1
24	male socket		4
25	24mm sleeve		4
26	34mm sleeve		4
27	71mm sleeve		2
28	75mm sleeve		2

UNLESS OTHERWISE SPECIFIED: DIMENSIONS ARE IN MILLIMETERS		FINISH: m8x75 rod		DEBURR AND BREAK SHARP EDGES		DO NOT SCALE DRAWING		REVISION 4	
SURFACE FINISH:									
TOLERANCES:									
LINEAR:									
ANGULAR:									
DRAWN		NAME		SIGNATURE		DATE		TITLE:	
CHK'D									
APPV'D									
MFG									
Q.A								MATERIAL:	
								DWG NO. PSP_AUS STD	
								A3	
								WEIGHT:	
								SCALE:1:20	
								SHEET 1 OF 2	

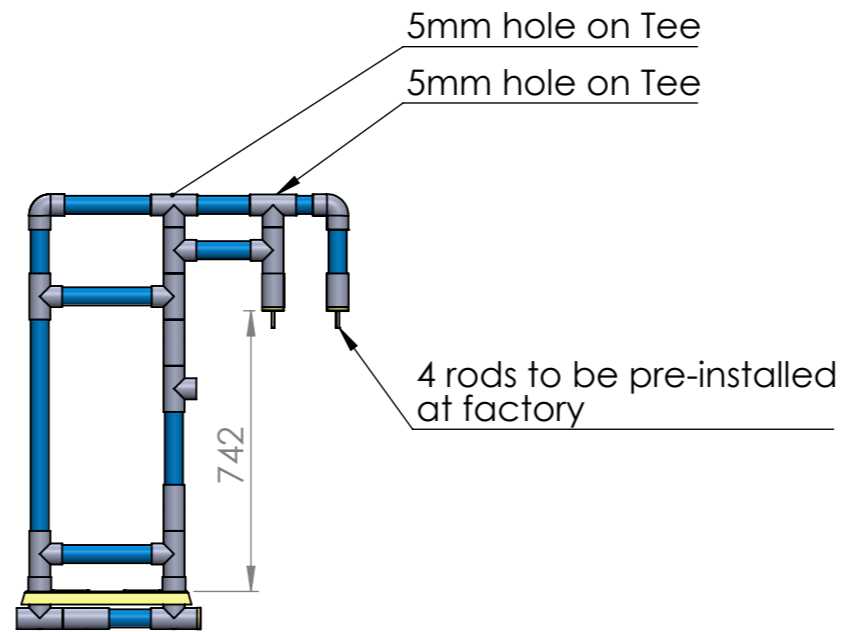
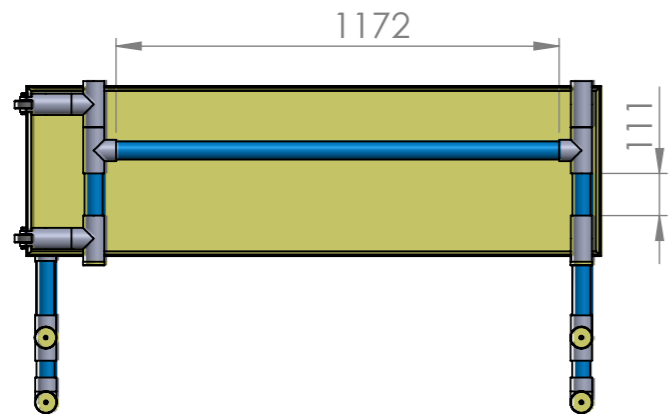
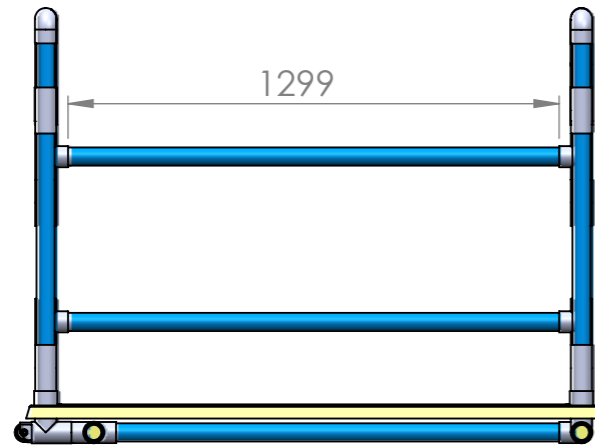
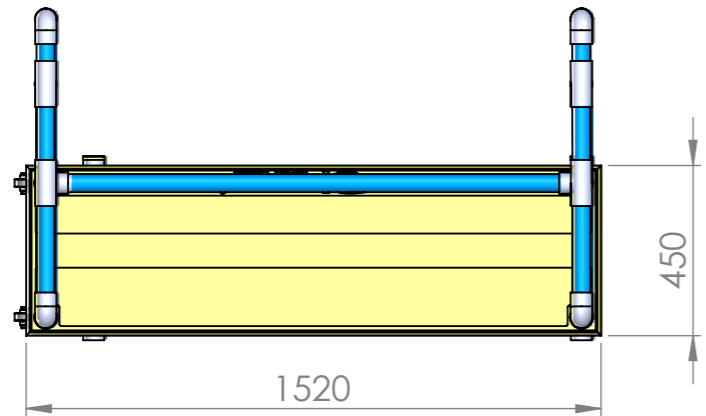

UNLESS OTHERWISE SPECIFIED: DIMENSIONS ARE IN MILLIMETERS				FINISH:		DEBURR AND BREAK SHARP EDGES		DO NOT SCALE DRAWING		REVISION	
SURFACE FINISH:											
TOLERANCES:											
LINEAR:											
ANGULAR:											
DRAWN		NAME		SIGNATURE		DATE		TITLE:			
CHK'D											
APPV'D											
MFG											
Q.A								MATERIAL:		DWG NO.	
										PSP_AUS STD	
								WEIGHT:		SCALE:1:20	
										SHEET 2 OF 2	
										A3	