

DETAIL B  
SCALE 1 : 4

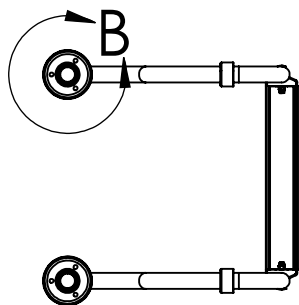

TUBING LENGTH: 89.17"

UNLESS OTHERWISE SPECIFIED  
DIMENSIONS ARE IN INCHES,  
TOLERANCES ARE:  
FRACTIONAL: ..... ±1/16  
ANGULAR: ..... ±1°  
TWO PLACE DECIMAL: .... ±.06  
THREE PLACE DECIMAL: .. ±.031

DESCRIPTION:

TWO-STEP LADDER - FLANGED,  
316L, 38MM X 1.2MM

MATERIAL:

1.50 x .049 (316L) S/S

PART NO.: SL-SF-2

REV. A

DRAWN BY: DTJ

DATE: 1/9/14

CHECKED BY:

DATE:



P.O. BOX 400 - 1017 S.W. BERG PARKWAY  
CANBY, OREGON 97013  
PHONE (503) 266-2231

REVISIONS			
REV.	DESCRIPTION	DATE	ECN

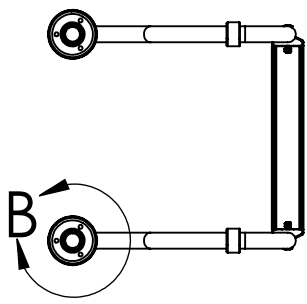
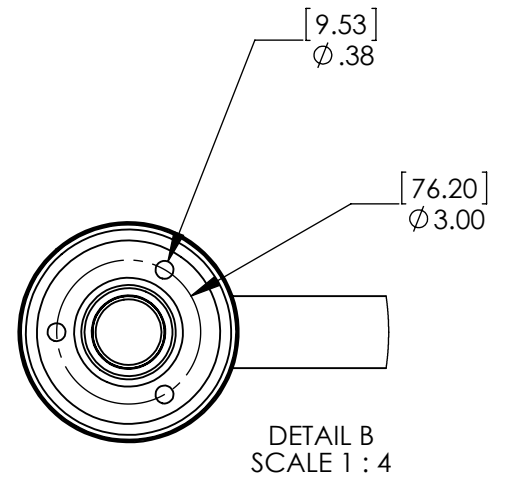
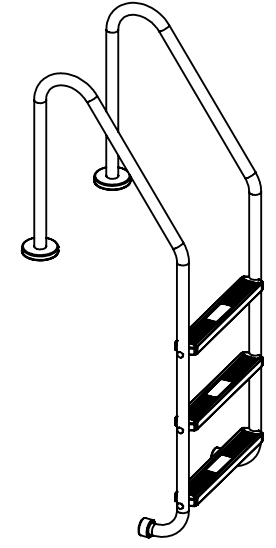
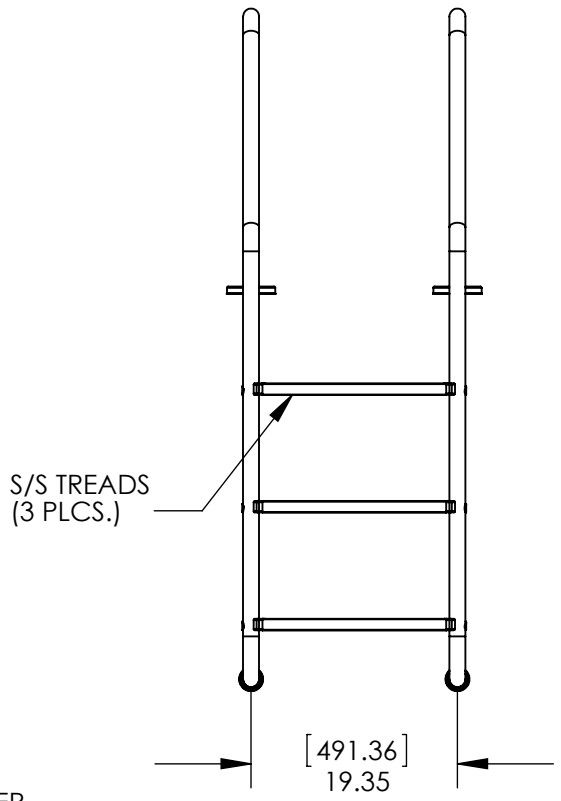
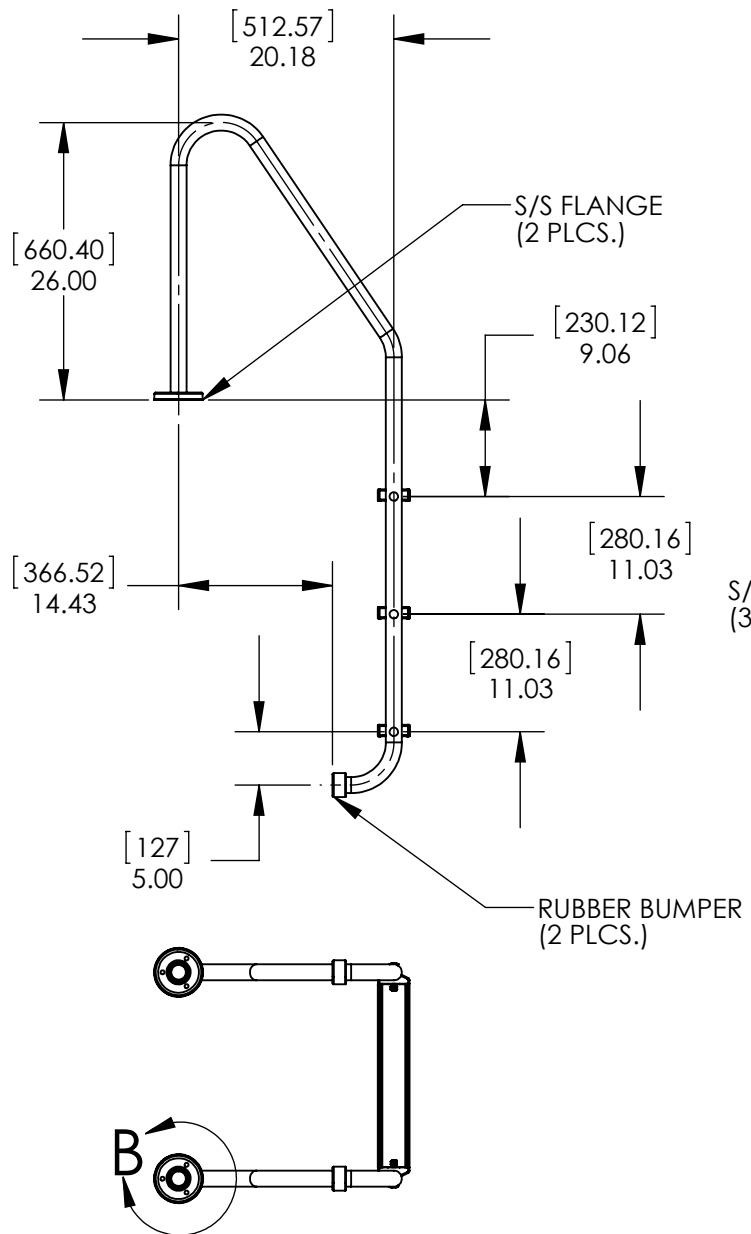

UNLESS OTHERWISE SPECIFIED  
DIMENSIONS ARE IN INCHES,  
TOLERANCES ARE:  
FRACTIONAL: ..... ±1/16  
ANGULAR: ..... ±1°  
TWO PLACE DECIMAL: .... ±.06  
THREE PLACE DECIMAL: .. ±.031

DESCRIPTION: THREE-STEP LADDER - FLANGED, 316L, 38MM X 1.2MM	
MATERIAL: 1.50 x .049 (316L) S/S	
PART NO.: SL-SF-3	REV. A
DRAWN BY: DTJ	DATE: 1/9/14
CHECKED BY:	DATE:

**SR Smith™**  
P.O. BOX 400 - 1017 S.W. BERG PARKWAY  
CANBY, OREGON 97013  
PHONE (503) 266-2231

SIZE: A SCALE: 1:18 SHEET 1 OF 4