



Velocity Advantage Starting Platform

ASSEMBLY AND INSTALLATION INSTRUCTIONS



SRS AUSTRALIA, PTY LTD
12 Enterprise St
Richlands QLD 4077
Australia
Phone 07 3812 2283 • Fax 07 3812 1187
www.srsmith.com/au

S.R. SMITH, LLC
CORPORATE HEADQUARTERS
P.O. Box 400 • 1017 S.W. Berg Parkway
Canby, Oregon 97013
USA
Phone (503) 266 2231 • Fax (503) 266 4334
www.srsmith.com

Table of Contents

INTRODUCTION.....	2
VELOCITY ADVANTAGE LAYOUT.....	3
PARTS LIST.....	4
ANCHOR INSTALLATION.....	5
VELOCITY ADVANTAGE INSTALLATION INSTRUCTIONS.....	6
BACKSTROKE LEDGE ADJUSTMENT.....	7
WARRANTY & PRODUCT REGISTRATION INFORMATION.....	7
APPENDIX A FULL PARTS LIST.....	8

INTRODUCTION



DANGER – FAILURE TO FOLLOW THESE WARNINGS, INSTRUCTIONS, AND THE OWNER’S MANUAL MAY RESULT IN SERIOUS INJURY OR DEATH.

The Velocity Advantage Starting Platform is designed for use on competitive or municipal pools. Proper installation, use, and maintenance are essential for proper operation and to reduce the risk of serious injury or death.

All national and local building codes must be followed. This includes any applicable requirements for size of concrete footing and bonding or electrical codes.

Check entire box and inside all packing materials for parts. Before beginning assembly, read the instructions and identify parts using the figures and parts listed in this document. It is critical that all parts be carefully inspected by the installer prior to installation to ensure that no damage occurred in transit and that a damaged part is not used. Proper installation cannot be overstressed, as an improper installation voids S.R. Smith’s warranty and may affect the safety of the user.

Installer must give the owner the Velocity Advantage Starting Platform installation manual.

VELOCITY ADVANTAGE LAYOUT

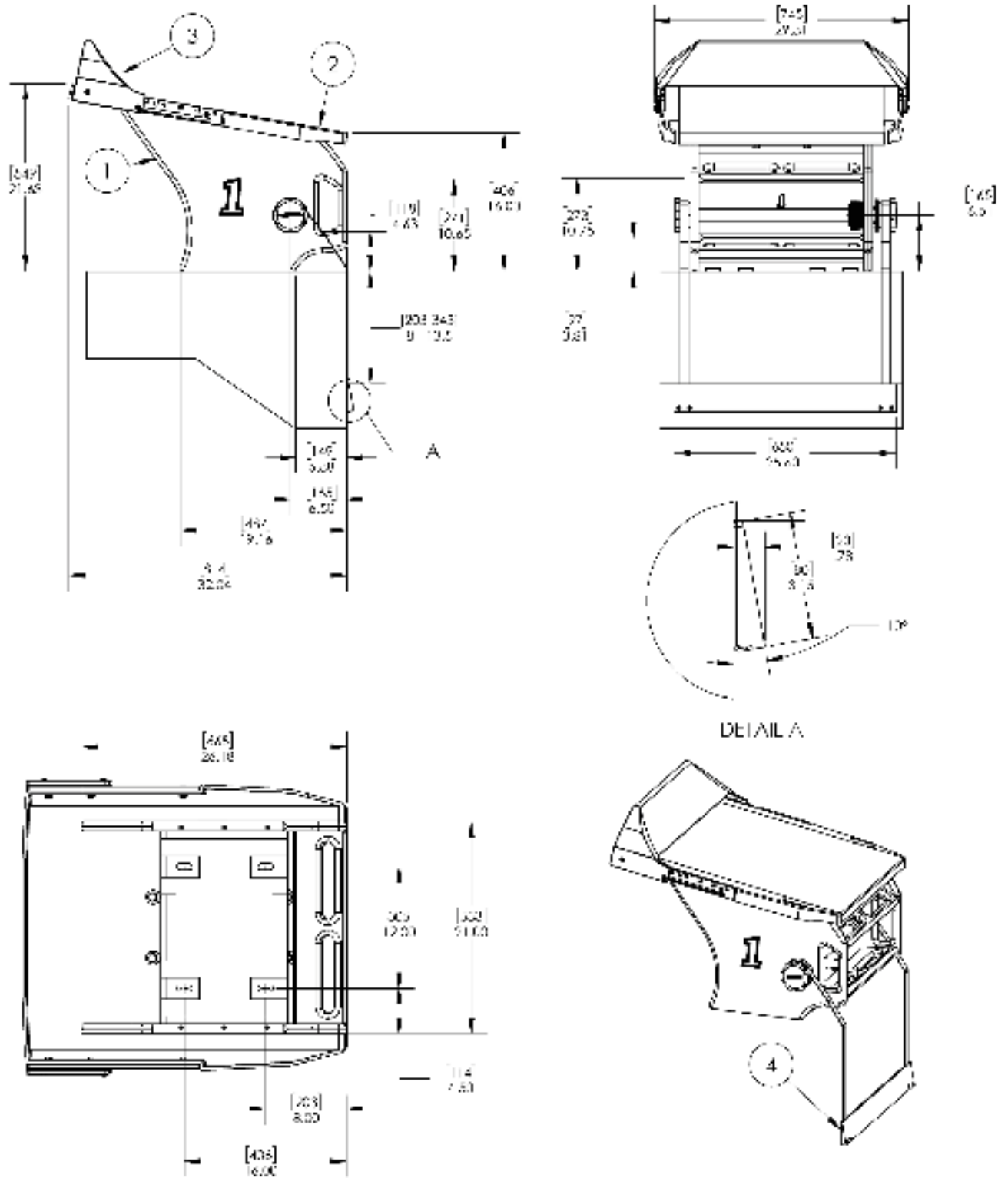

Figure 1 | Velocity Advantage Dimensions

PARTS LIST

ITEM NO.	QTY.	PART NO.	DESCRIPTION
1	1	VELO-ADV-BK	STARTING PLATFORM ASSEMBLY
2*	1	27-111-1	VELOCITY ADVANTAGE ANCHORING JIG
3*	4	800-0132	NUT
4*	4	300-6700	FLUSH DECK ANCHORS
5*	4	05-618	PLASTIC NUT CAP, 1/2"
6*	4	5-125-1	1/2-13 x 3-1/2" LONG HEX HEAD CAP SCREW, FULLY THREADED
7*	4	05-14-115	1/2" LOCK WASHER S/S
8*	4	05-14-114	1/2" FLAT WASHER S/S

*Anchoring kit (27-111) sold separately.

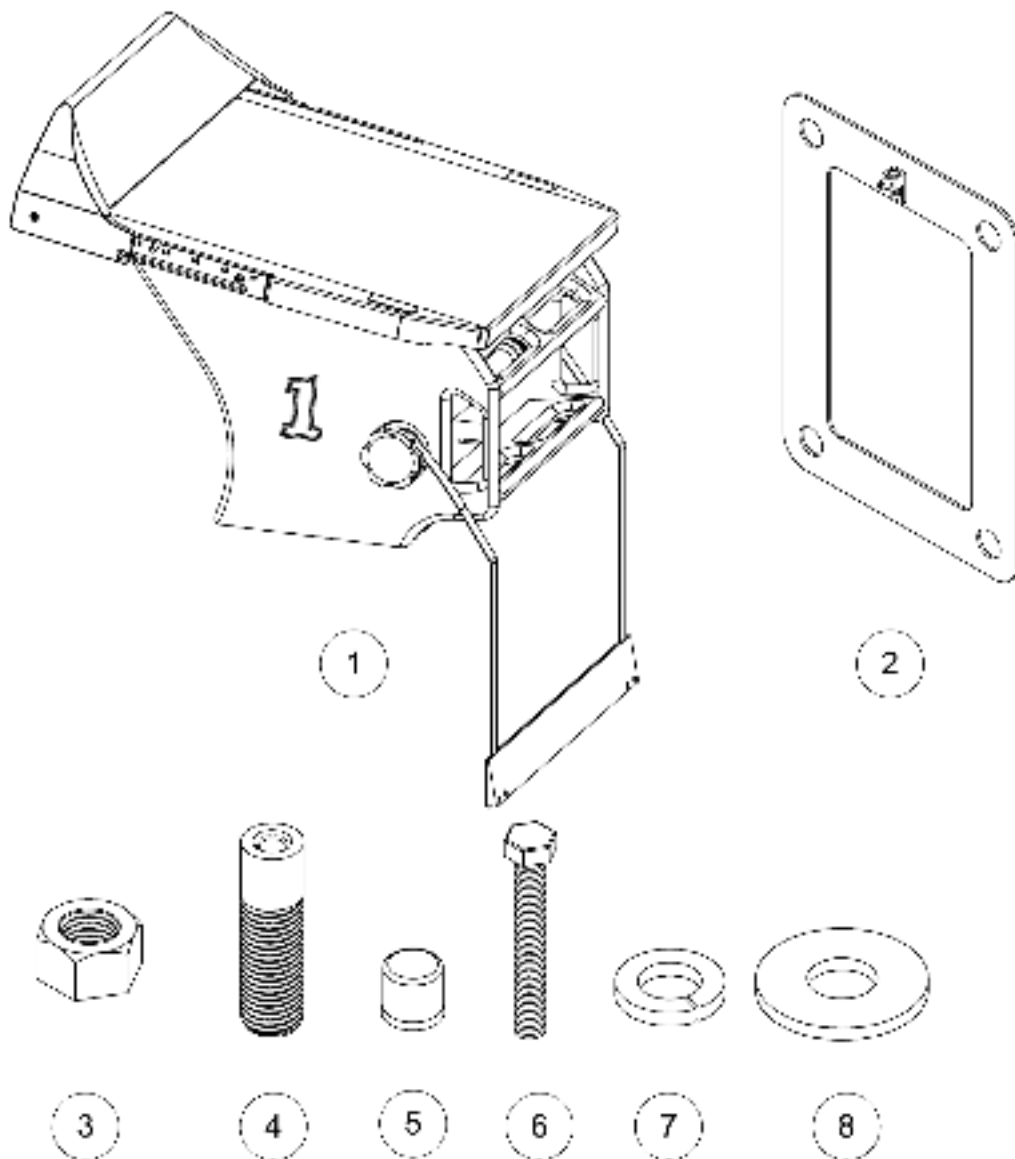

Figure 2 | Velocity Advantage Parts

ANCHOR INSTALLATION

Ensure the anchors have been installed in the correct location in the pool deck for conformance to competition standards. The mounting distance for the deck front anchors is 8" (203mm) from the edge of the pool. It is recommended that the anchor be installed by a person familiar with installing pool deck equipment. The pool owner is responsible for ensuring that all applicable ordinances are followed when installing the starting platform.

- 1 Assemble the Velocity Advantage Anchoring Jig by threading the flush deck anchor as shown in Figure 3 until the top of each flush deck anchor is 2.5" (63.5mm) from the top of the anchoring plate. Measure to verify.

Table 1

ITEM NO.	PART NO.	DESCRIPTION	QTY.
1	4-178	Velocity Advantage Anchor Jig Plate	1
2	800-0132	Hex Nut, 1"-8 Galvanized Steel	8
3	300-6700	Flush Deck Anchor	4

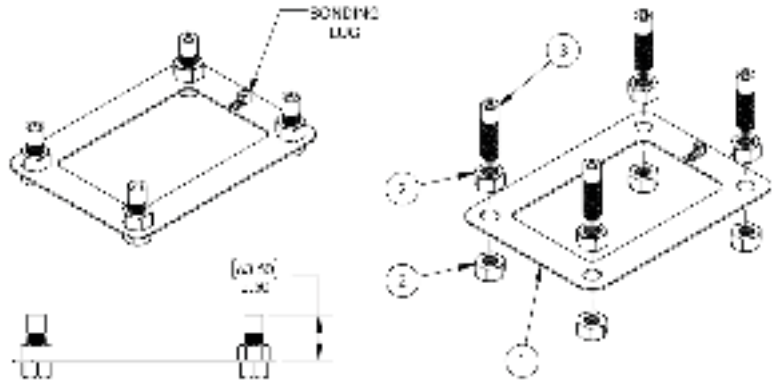

Figure 3 | Anchor Jig Assembly

- 2 Install the anchor jig. Ensure the following:
 - a. Tops of anchors are flush with the top of the slab.
 - b. The centers of the front anchors are 8" from the pool wall.
 - c. The long edge of the anchor jig is parallel to the edge of the slab.
- 3 Use the bonding lug provided on the anchor jig to attach the bonding wire per local codes. Contact your local Authority having jurisdiction for the bonding requirements in your area.
- 4 Allow concrete to cure per manufacturer's instructions.

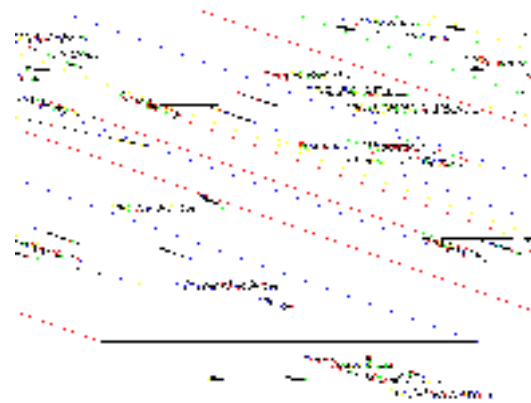

Figure 4 | Anchor Installation Plan View



Figure 5 | Anchor Installation Layout, Side View

VELOCITY ADVANTAGE INSTALLATION INSTRUCTIONS

Tools Required:

3/4" Wrench or Socket Wrench.

1. Align starting platform base slots with the deck anchors. Ensure the front of the starting platform is flush with the pool wall.
2. Fasten the Velocity Advantage to the anchors as shown in Figure 6. **Use a 3/4" socket or wrench** to tighten the bolts until the lock washers are fully compressed.

Use anti-seize compound on the stainless-steel mounting bolts to prevent seizing in the deck anchors.

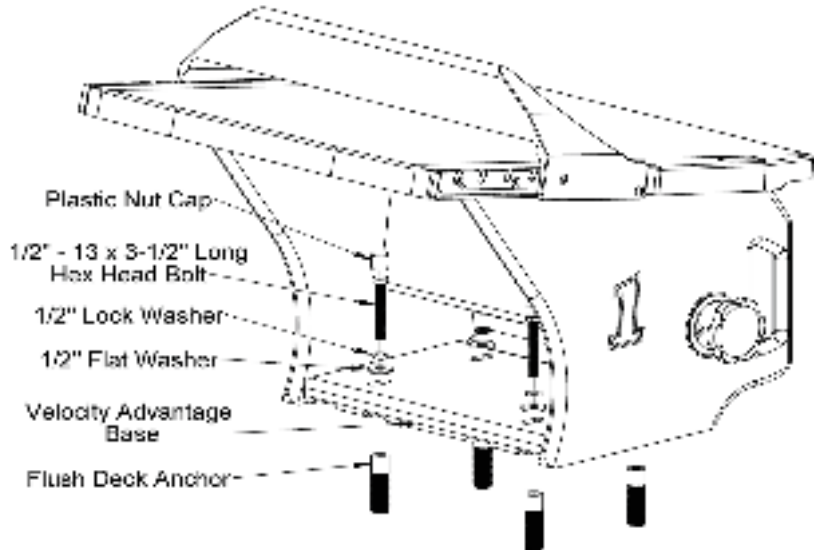

Figure 6 | Mounting Hardware

3. Set the backstroke ledge in the pool, looping the strap around and over the spool cap. Ensure adjustment is initially set at 0 as shown in Figure 7. Verify the top of the ledge is at water level within 1/2" (13mm).

Contact either your distributor or S.R. Smith if the strap is too short; we will replace it with one that is the right length for your deck-to-water height.

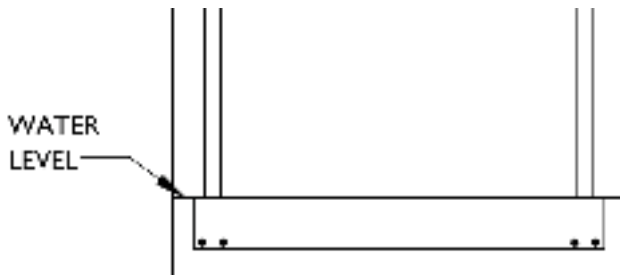

Figure 7 | Backstroke Ledge Alignment

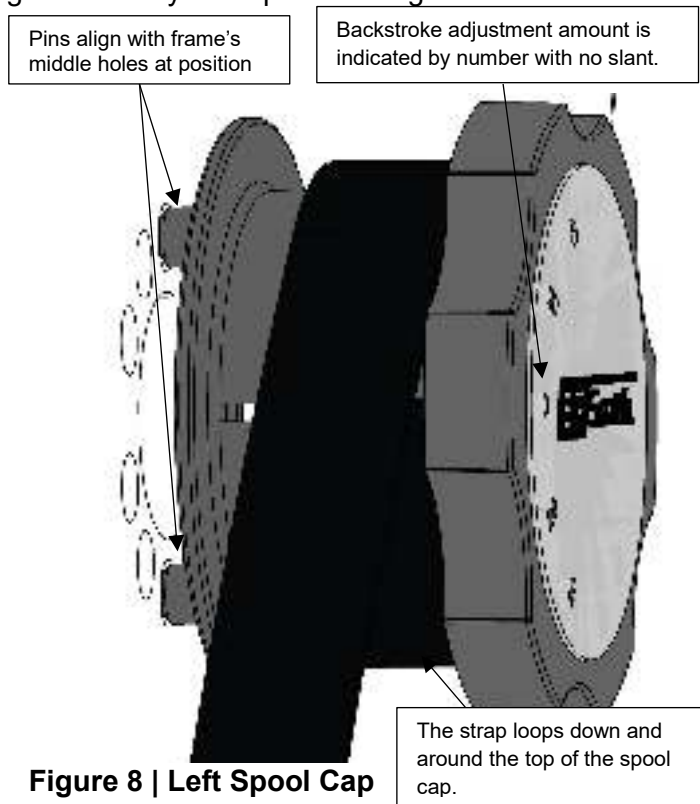

Figure 8 | Left Spool Cap

BACKSTROKE LEDGE ADJUSTMENT

The backstroke ledge can be adjusted 40mm (1.6") above or below the water level in increments of 20mm (5 positions). To adjust the height, follow these instructions:

- 1 Pull on the left spool cap until the pins are clear of the holes in the frame. The left spool cap is marked with numbers.
- 2 Rotate the spool to the desired depth. Rotating clockwise will raise the backstroke ledge above water level. Rotating counter-clockwise will lower the backstroke ledge.
- 3 Align the pins with corresponding holes in the frame and push the left spool cap back in.

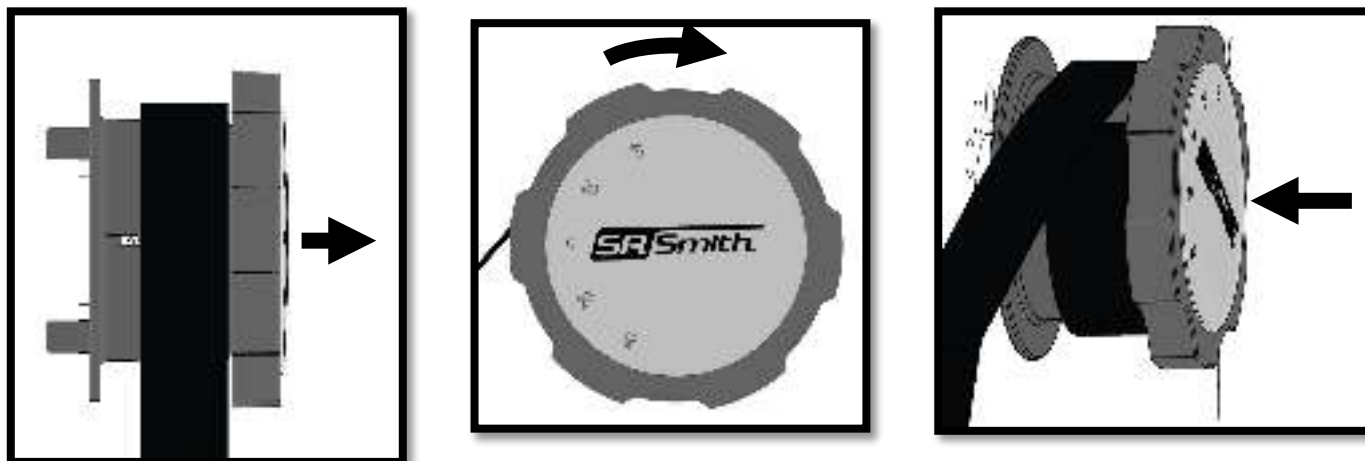

Figure 9 | Backstroke Ledge Adjustment

WARRANTY & PRODUCT REGISTRATION INFORMATION

For warranty information and details, please visit

www.srsmith.com/en-us/customer-service/warranty-information/

Register your S.R.Smith product at www.srsmith.com/en-us/customer-service/product-registration



Visit srsmith.com for information on the complete line of S.R.Smith pool products.

SAFETY & MAINTENANCE INSTRUCTIONS

- **Execute shallow racing dives only.**
- For use by trained competitive swimmers only.
- Inspect the Velocity Advantage monthly to assure there are no worn parts and that all hardware is properly tightened.
- To clean, use a multi-purpose cleaner and scrub lightly with a nylon scrubby or brush.

APPENDIX A | FULL PARTS LIST

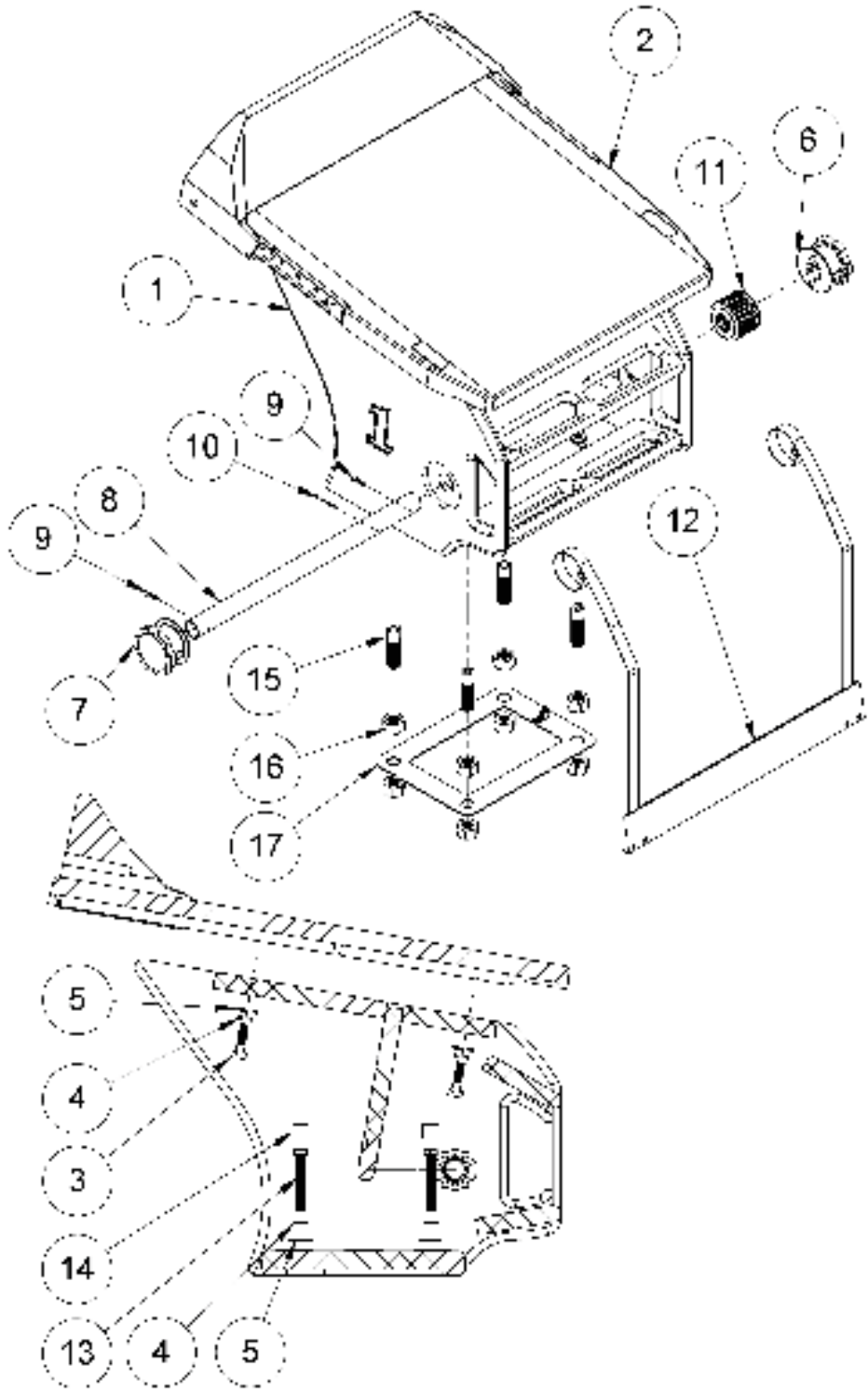

ITEM NO.	PART NO.	DESCRIPTION	VELO-ADV-BK QTY.	ANCHOR KIT* QTY.
1	03-600	Velocity Advantage Frame	1	
2	8-620TS	Hex Nut, 1"-8 Galvanized Steel	1	
3	5-169	½"-13 x 1 ¾" Hex Head Cap Screw, S/S	4	
4	05-14-115	½" Lock Washer, S/S	4	4
5	05-14-114	½" Flat Washer, S/S	4	4
6	05-700L	Left Spool End Assembly	1	
7	05-700R	Right Spool End Assembly	1	
8	09-239-2	Spool Shaft	1	
9	05-14-118	¼"-14 x 1.25" Self-Tapping Screw	2	
10	05-14-120	Spring Pin, 1/8"Ø x 2"	1	
11	08-151A	Bellows Assembly	1	
12	03-650A	Backstroke Ledge Assembly	2	
13	5-125-1	½"-13 x 3 ½" Full Thread Hex Head Cap Screw	-	4
14	05-618	½" Plastic Nut Cap, White	-	4
15	300-6700	Flush Deck Anchor, ½"-13 x1.75" Internal Thread, 1"-8 x 2.5" External Thread	-	4
16	800-0132	1"-8 Hex Nut, 18-8 Steel	-	8
17	27-111-1	Anchor Jig Assembly	-	1

Anchoring kit (27-111) is sold separately.